



POLICY DISCUSSION PAPER

# THE IMPACT OF NETWORK USAGE FEES ON THE BRAZIL CLOUD MARKET

David Abecassis, Michael Kende, Andrew Daly, Tanmay Tyagi

FEBRUARY 2024



# Contents

<b>Executive summary</b>	<b>1</b>
<b>1 Introduction and Brazil's digital ambitions</b>	<b>5</b>
<b>2 Public CDN and cloud are intermediaries that underpin quality and innovation on the internet</b>	<b>10</b>
2.1 Public CDNs support the consumption of popular content in Brazil	10
2.2 Public cloud services are supporting critical industries and sectors	13
<b>3 Public CDN and cloud services have a mutually beneficial relationship with ISPs</b>	<b>19</b>
3.1 The benefits of CDN and cloud providers' services to ISPs	19
3.2 Cloud and CDN providers have invested significantly to support internet services	22
<b>4 Imposing fees risks harming the development of Brazil's digital economy</b>	<b>24</b>
4.1 Mandated fees on public CDNs and cloud providers would result in adverse incentives to invest, more capacity bottlenecks, and higher prices to their users	24
4.2 Snowball effect on businesses, public sector cloud users and consumers	27
4.3 Technical and practical challenges with imposing regulation	28
<b>5 Conclusions</b>	<b>31</b>

---

Prepared for dissemination with support from the Computer & Communications Industry Association Research Center.

Copyright © 2024. The information contained herein is the property of Analysys Mason and is provided on condition that it will not be reproduced, copied, lent or disclosed, directly or indirectly, nor used for any purpose other than that for which it was specifically furnished.

---

Analysys Mason Limited  
North West Wing, Bush House  
Aldwych  
London WC2B 4PJ  
UK  
Tel: +44 (0)20 7395 9000  
london@analysismason.com  
www.analysismason.com  
Registered in England and Wales No. 5177472

## Executive summary

*Policymakers in Brazil are considering mandating direct payments to ISPs from other networks for internet interconnection, in the form of network usage fees*

Policymakers in Brazil are considering regulation that would enforce mandated payments (network usage fees) from large online content and application providers (CAPs) to telecoms operators (i.e., internet service providers, ISPs). These payments would be in addition to the payments that ISPs receive from end users.

We find that the imposition of network usage fees would create frictions, costs, and disruptions to a very dynamic set of services which require high investments. This could result in increased costs for the substantial number of organisations, enterprises and businesses, of a wide range of sizes and from a wide range of sectors. This in turn could limit adoption of those cloud services, something which is key to achieving the digital transformation ambitions of the government of Brazil.

We have addressed the rationale and impact of network usage fees in previous papers, highlighting the lack of cost-based justification for such charges in most cases, and the potential impact of mandated traffic-related charges on the architecture and functioning of the internet.<sup>1</sup> In this paper we focus specifically on the impact of such payments if they were applied to providers of public content delivery networks (CDNs) and public cloud services.

We note that the European Commission has refrained from introducing network fees before their current mandate ends in November 2024. While this paper focuses on the situation in Brazil, the overall conclusions on the detrimental impact of network usage fees would be similarly applicable in other countries, including those in the wider Latin America region.

*Brazil has set out its ambitions to transform its digital economy*

The Brazilian government, through the Ministry of Science, Technology and Innovations (MCTI), has set out a range of clearly defined objectives for the transformation of its digital economy in the Brazilian Digital Transformation Strategy (E-Digital)<sup>2</sup> for 2022–2026. The strategy includes *enabling axes*, which aim to build the foundations for digital transformation, and *digital transformation axes*, which include strategies that are aimed at digital transformation of government and economic activities, based on the foundations developed in the enabling axes.

<sup>1</sup> See for example Analysys Mason (2022), *IP interconnection on the Internet: a European perspective for 2022*

<sup>2</sup> Ministry of Science, Technology and Innovations (2022), *Brazilian digital transformation strategy (E-Digital)*

Many of these axes will be strongly influenced by cloud services, including the promotion of secure networks, long-term investment in compute and storage infrastructure, and the promotion of research, development and innovation – leveraging advanced functionalities that are increasingly available on cloud platforms (including AI). Promoting transformative digital initiatives to small and medium-sized businesses is a key axis as well, including through the adoption of digital and cloud-based services.

*Public CDN and cloud are intermediaries that underpin quality and innovation on the internet*

A wide range of businesses and public sector stakeholders buy services from public CDNs and cloud service providers, to support their IT and digital activities. These services include computing, storage and networking resources. Many users of cloud services access them through the internet and therefore rely on their ISP being connected, directly or indirectly, to the cloud infrastructure service provider of their choice. In some cases, public CDNs are used by companies seeking to reach their own customers, for example through a website or app. A good example of this dynamic is how TV broadcasters deliver their on-demand video services to end users: their business is TV, not computing and networking, and therefore they rely on public cloud and CDNs as a technical input into the delivery of their service to viewers. These services can therefore be viewed as ‘technical intermediaries’ between a content or service provider such as a TV channel and end users (in this example, TV viewers).

Public CDNs support a good quality of experience for end users of internet services by replacing the unmanaged ‘best efforts’ approach to conventional internet traffic routing with an optimised service. This approach ensures that content requests from end users are served promptly and reliably: web pages load quickly and videos stream smoothly. Public cloud services allow enterprise users to benefit from the economies of scope and scale provided by sharing high-powered remote IT infrastructure with other enterprises. Cloud services are ‘elastic’ as capability can be provided (and cost incurred) on-demand. It is possible to obtain significant computing power as required and only pay for the time that computing power is used. For cloud services, the connectivity between the end user and public cloud platforms is critical, and ISPs play a vital role in providing the two-way connectivity that is a fundamental requirement.

Public CDN and cloud services provide a material input to the Brazilian digital economy. Popular online content services in Brazil use and pay for public CDNs, though the overall picture involves multiple stakeholder relationships. Many content sources use multiple CDN providers, and many CDNs support multiple media companies. Similarly, public cloud services are already supporting day-to-day operations across a wide range of sectors of the Brazilian economy and society, including finance, education, healthcare, retail and consumer goods, technology, telecoms and transportation, as well as start-ups who can use cloud services to quickly reach the market. Examples of high-profile Brazilian companies using public cloud and CDN include Telecom Italia Mobile (TIM) and Globo.

*Public CDN and cloud services have a mutually beneficial relationship with ISPs*

ISPs and public CDNs working together benefits all parties. Without a CDN, each request for content must be served from the origin source, through national and sometimes international links: if the origin is in another country, the ISP will likely incur significant costs for IP transit to bring the content to subscribers on their network. CDNs significantly mitigate this effect by reducing traffic costs in the core part of the network. They also allow the customer of the CDN (the content provider) to internalise the costs of bringing content closer to the ISP and the end user, where the quality-of-service benefits outweigh the costs of using a CDN. This helps to ensure that internet services can be delivered to end users at the right price. And the benefit is further increased if the CDN places a cache inside the network of the ISP (even closer to the end user). Many ISPs and CDNs have agreed to this practice, as it is mutually beneficial (a better end user experience is good for both ISP and the CDN customers).

Public CDNs support the ongoing utility of internet services, and therefore demand for access to the internet. This effect supports, in turn, the ongoing demand for the services offered by ISPs. Similarly, cloud services require effective two-way connectivity provided by ISPs, creating further demand for internet access services that offer high bandwidth and reliability.

A final benefit to ISPs is possible if they make direct use of cloud services themselves. Some cloud services providers are working with ISPs (especially mobile network operators, MNOs) to help them develop new services and lower their costs, by migrating some of the IT and network functions to cloud infrastructure.

These benefits are being delivered via significant investment in data centres and cache/server equipment by CDN and cloud providers, both in Brazil and globally. A wide range of CDN and cloud providers have installed their equipment in a large number of towns and cities across Brazil, and the trend for the largest cloud providers appears to be further decentralisation of cloud infrastructure, largely interconnected, to bring compute and storage services even closer to end users.

*Network usage fees for CDN and cloud services would adversely impact end users*

The demand for online services is dependent both on the cost and quality of experience associated with these services for end users. Imposing network usage fees could increase costs and reduce quality, resulting in a negative impact on end users. Today, providers, including public cloud and CDN providers and ISPs, continue to voluntarily negotiate interconnection arrangements, as they have done since the earliest days of the internet. As new generations of access technology are introduced and new services made available on the internet, the interconnection arrangements have continued to evolve to ensure that interconnection is mutually beneficial, a process that has continued with the introduction and popularisation of public cloud and CDN services. The introduction of regulation and mandates for interconnection would change the balance of these negotiations, even when regulators do not specify a price level, which in turn would change the dynamics on which internet infrastructure is built.

Imposing the requirement to negotiate a network usage fee would enable ISPs to raise the fees in light of the termination monopoly they have for reaching their subscribers. Regulating the rate of the network usage fee may lower the network usage fee, but impose its own costs on the regulator in order to set the fee, monitor traffic and arbitrate disputes. Regardless of how the fee is set, it reduces the ability and incentive of cloud and CDN providers to invest in their networks, at the expense of the quality of experience for end users, and costs may be passed on as well. As all end users are directly and indirectly the beneficiaries of cloud and CDNs, all would be negatively impacted by the imposition of network usage fees.

*Imposing fees risks harming the development of Brazil's digital economy*

Brazil's digital readiness compares well to regional peers, but is still developing when compared to global leaders, in line with the goals of E-Digital. Public CDN and cloud services are supporting this progress: by supporting access to digital technologies with a good quality of service, by providing the right cyberinfrastructure, by supporting a data-based economy, by supporting new business models, and by facilitating the adoption of ICT solution for small and medium enterprises. Therefore, policymakers and regulators must ensure that any imposition of regulation does not adversely impede the ability of these services to underpin Brazil's digital ambitions.

# 1 Introduction and Brazil's digital ambitions

Brazil has ambitions to strengthen its digital economy and improve its position in the region and globally, through a comprehensive digital strategy. However, the proposed implementation of network usage fees on traffic delivered by content providers, including notably public CDN and cloud providers, will likely act counter to this ambitious plan.

*Brazil's digital economy leads in the region, but has scope to develop further globally*

Brazil is one of the leading digital economies in Latin America, but has work to do against more global comparators. The International Institute of Management Development (IMD) digital competitiveness ranking measures a country's capacity and readiness to adopt and discover digital technologies to facilitate economic transformation. The ranking takes into account three main factors i.e. knowledge, technology and future readiness. According to this ranking, Brazil ranked 52 out of 64 countries globally in 2022, showing significant improvement from 2019 where Brazil was ranked 57 out of 64 countries. When compared to other South American countries (Argentina, Chile, Colombia, Peru and Venezuela), Brazil's relative ranking was second out of the six countries, as illustrated in Figure 1.1.<sup>3</sup>

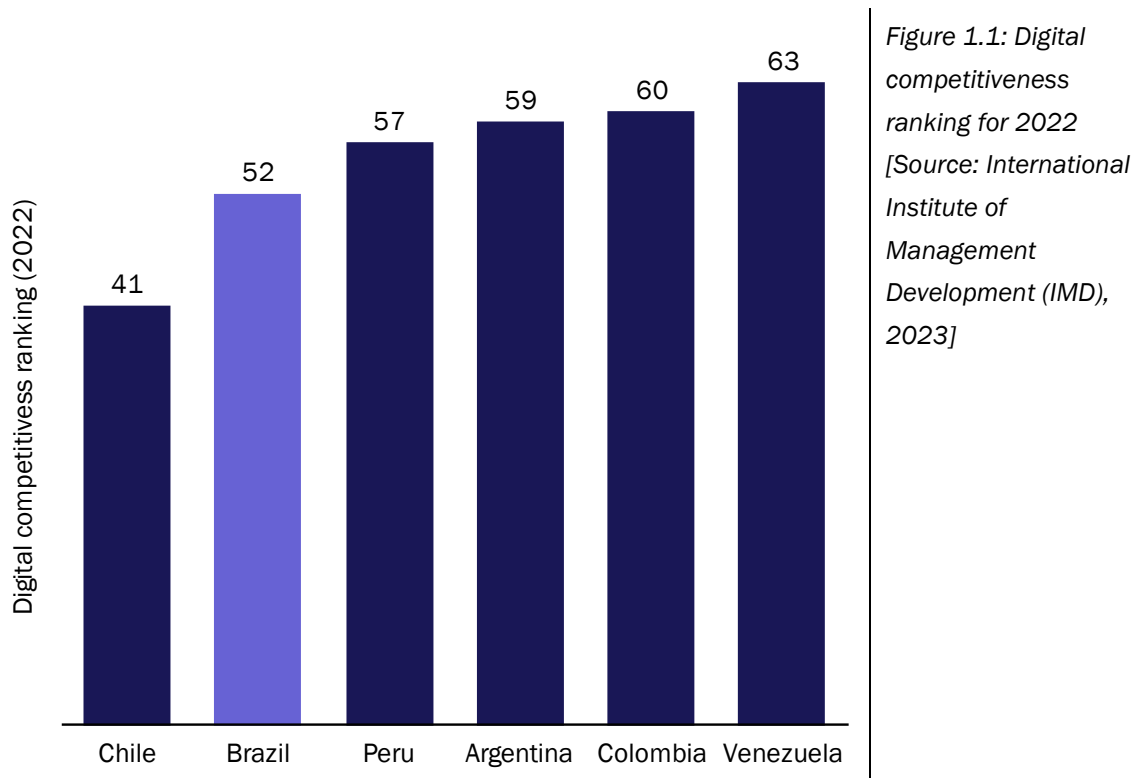

<sup>3</sup> See <https://worldcompetitiveness.imd.org/countryprofile/BR/digital>



Specifically for cloud services, we have referred to the MIT Technology Review Global Cloud Ecosystem Index 2022, which considers the ability of technology, regulations and talent in a country to promote the availability of cloud services. Within this, Brazil ranked 52 out of 76 countries in 2022. Brazil again ranked well compared to other countries in Latin America, including Argentina (48), Chile (37), Colombia (57), Ecuador (62), Paraguay (63), Peru (58) and Uruguay (39), as shown in Figure 1.2.<sup>4</sup>

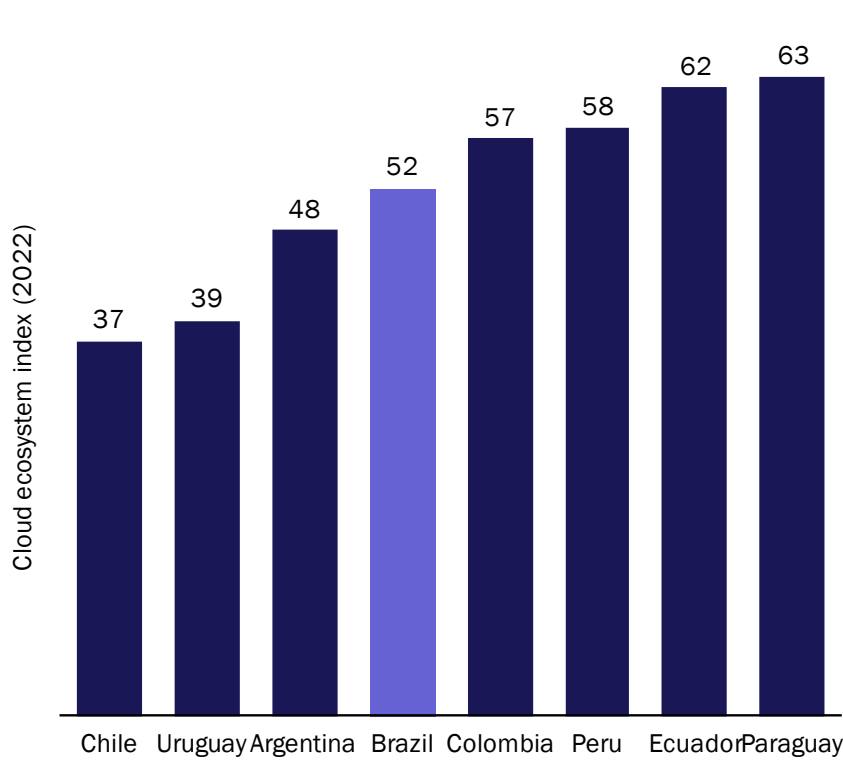

Figure 1.2: Global cloud ecosystem index for 2022 [Source: MIT technology review, 2023]

### *Brazil has set out its ambitions to transform its digital economy*

The Brazilian government (Ministry of Science, Technology and Innovations (MCTI)) has set out a range of clearly defined objectives for the transformation of its digital economy in the Brazilian Digital Transformation Strategy (E-Digital)<sup>5</sup> for 2022–2026. The strategy presents objectives for digital inclusion, deployment of digital infrastructures, information security, cyber security, professional training and technological development. E-Digital is based on two main axes:

- enabling axes – which aim to build the foundations for digital transformation
- digital transformation axes – which include strategies that are aimed at digital transformation of government and economic activities, based on the foundations developed in the enabling axes.

<sup>4</sup> MIT Technology Review (2022), *Global Cloud Ecosystem Index 2022*

<sup>5</sup> Ministry of Science, Technology and Innovations (2022), *Brazilian digital transformation strategy (E-Digital)*

There are five enabling axes of E-Digital with a general objective defined for each axis, as presented in Figure 1.3.

Figure 1.3: General objectives of enabling axes [Source: MCTI, 2023]

Enabling axes	General objective
A. Infrastructure and access to information and communication technologies	Expand the population's access to internet and digital technologies whilst ensuring quality of service and cost effectiveness
B. Research, development and innovation	Encourage the development and expansion of new technologies and find solutions for national challenges
C. Trust in the digital government	Ensure a secure and reliable digital environment which is favourable for usage and providing services; and respects citizen's rights
D. Education and professional training	Provide training to the society for advanced technologies and prepare the workforce of the future
E. International dimension	Strengthen Brazil's leadership in global forums on digital issues, encourage the presence and competitiveness of Brazilian companies in other countries and promote regional integration in the digital economy

As part of E-Digital 2022–26, the general objectives of the enabling axes and digital transformation axes are proposed to be met by implementing a range of strategic actions. Some of the proposed strategic actions for enabling axes for 2022–26 which are relevant to this paper include:

- *“Promote the deployment of secure networks (covering connectivity, processing, and storage resources) to integrate research, education, and health institutions into high-speed networks, stimulating scientific and technological exchange while benefiting populations located in remote regions”*
- *“Make long-term investments and coordination between initiatives of data communication infrastructure, computing (such as high performance computing - HPC) and data storage, in order to meet the needs of cyberinfrastructure services for large science and technology projects, in cooperation with companies in high demand of ICT [information and communication technology], supporting RD&I [research, development and innovation] projects in this sector”*
- *“Promote RD&I, including through government technology orders, in strategic themes for digital transformation, such as internet of things (IoT), artificial intelligence, robotics, automation, cloud computing, blockchain....”*

The four digital transformation axes and their associated general E-Digital objectives are presented in Figure 1.4.

Figure 1.4: General objectives of digital transformation axes [Source: Ministry of Science, Technology and Innovations (MCTI), 2023]

Digital transformation axes	General objective
Digital transformation of the economy: data-based economy	Foster computerisation, productivity, dynamism and competitiveness of the economy to keep up with the world economy
Digital transformation of the economy: a world of connected devices	
Digital transformation of the economy: new business models	
Citizenship and digital transformation of the government	The provision of federal government services should be in line with the digital advancements

Some of the proposed strategic actions for digital transformation axes for 2022–26 that are relevant to this paper include:

- *“Promote and foster the mass adoption of ICT solutions for small and medium-sized enterprises (SME)”*
- *“Create mechanisms to encourage access to computers, cell phones, devices, tablets, software, and cloud storage services for individual microentrepreneurs (MEI), strengthening the adoption of digital business models”*

Although Brazil’s cloud market seems to be doing well compared to other countries in the region, it is still developing in the global context. Brazil’s E-Digital strategy has set out the framework for that development to take place, and public CDN and cloud services are effectively supporting a number of the elements of the strategy.

- The use of CDNs by major media providers is supportive of Brazil’s e-digital ambitions, in particular, supporting access to internet and digital technologies with good quality of service, and allowing the development of new business models (e.g. traditional telecoms operators or TV broadcasters reaching online audiences).
- The use of cloud services by Brazilian enterprises is delivering against a number of the elements of E-Digital, including:
  - access to digital technologies
  - development and expansion of new technologies
  - providing the cyberinfrastructure needed for large science and technology projects
  - supporting a data-based economy
  - supporting new business models
  - promoting the adoption of ICT solutions for small and medium-sized enterprises.

*Policymakers are considering network usage fees, which would significantly impact the functioning of public cloud platforms and CDNs, to the detriment of Brazil's digital economy ambitions*

Policymakers in Brazil are considering regulation which would impose mandated payments (network usage fees) from large online content and application providers (CAPs) to telecoms operators (i.e., internet service providers, ISPs). These payments would be in addition to the payments that ISPs receive from their subscribers, the end users, and any currently negotiated interconnection payments that some telecom operators receive for transit and paid peering.

When considering how the application of such fees to CAP services may affect the full range of online activities, it is useful to split those activities into three broad categories:

- the direct delivery of content requested by end users through the internet, which includes the provision of video on demand streaming services, websites and social media
- the delivery of content through CDNs, which support the efficient delivery of content, from the source (origin) to the end user. CDNs can be private (whereby the CDN only supports the content of one CAP), or public (whereby the CDN supports content from a range of providers).
- the exchange of data in the context of interactions with cloud services by end users (including businesses of all sizes); this includes the remote provision of compute, storage and analysis services.

In this report we focus on how public CDNs and public cloud services are helping to support the ambitions laid out in Brazil's E-Digital strategy. We explain that public CDNs and public cloud services intrinsically benefit a wide range of businesses and end users in Brazil. This provides a backdrop to a discussion of how the imposition of network usage fees on public cloud and CDNs could be detrimental to the ongoing development of the internet and the digital economy in Brazil.

The remainder of this document is laid out as follows:

- Section 2 describes public CDN and cloud services in Brazil
- Section 3 explains how public CDN and cloud providers are beneficial to ISPs
- Section 4 discusses the potential impact of network fees on public CDNs and cloud
- Section 5 presents our conclusions.

## 2 Public CDN and cloud are intermediaries that underpin quality and innovation on the internet

Public CDN and cloud services are intermediary services that allow end users and content sources to interact over the internet. They are not sources of content, but facilitate access to content by delivering innovative and value-adding services with a good quality of experience, and reducing the overall cost required for traffic to flow between the origin and the end user. In this section we explain how public CDNs and cloud services deliver these benefits.

Throughout the section, we give examples of how these services are supporting key elements of the Brazilian economy, and highlight where the services are directly supporting Brazil's digital transformation goals.

### 2.1 Public CDNs support the consumption of popular content in Brazil

In this section, we explain how public CDNs support a good quality of experience for end users of internet services, by replacing the unmanaged 'best efforts' approach to conventional internet traffic routing with an optimised service.

#### 2.1.1 Public CDNs bring improvements to the end user experience

The primary purpose of public CDNs is to improve the experience of end users consuming services over the internet. To understand this effect, it is useful to start with a simple characterisation of how information and data flow over the internet, as shown in Figure 2.1.

Figure 2.1: Overview of traffic flows across the public internet [Source: Analysys Mason, 2023]

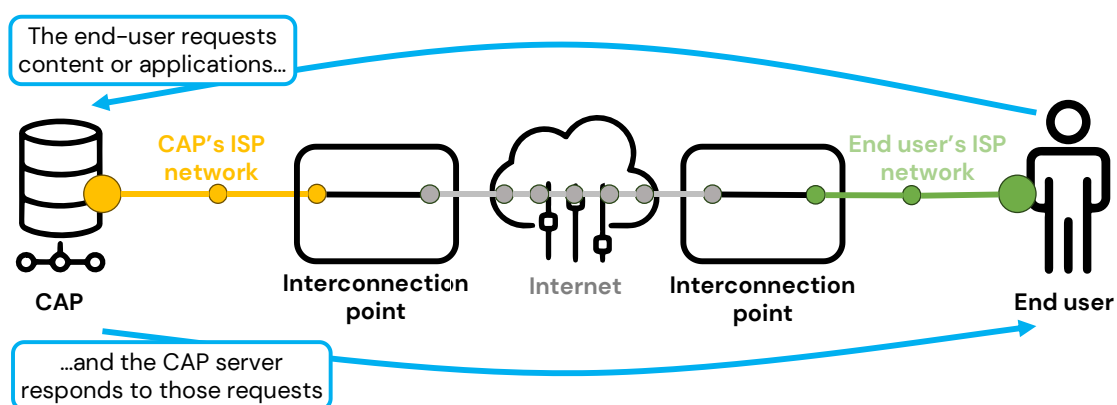

Information and data flow across the public internet through multiple interconnected networks who hand over traffic made out of 'packets', which are bits of information that are addressed from a point A (the origin) to a point B (the destination). These packets are routed across interfaces between

networks following a ‘best efforts’ approach, passing on the packet to the nearest network that is a) available and b) is shown as being able to reach the destination. As a result, ISPs connect origins and end users through interconnection mechanisms that are (by design) not controllable end-to-end. Between the origin and destination points, there is potential for congestion due to a lack of control over the traffic, lack of service level agreements (SLAs), etc. This congestion – along with the number of network nodes between the origin to end user – can harm the user experience (i.e. content is delivered slowly and/or unreliably).

A CDN brings data traffic to interconnection points closer to end users. They do this through a combination of their own ‘managed’ network taking traffic from the content source to a point close to the destination, and sometimes further reduce this distance by storing content in caches.

The first function of a CDN is to control the routing and optimisation of traffic between the origin server and the local interconnection point. Reducing the number of routers and the geographical distance significantly reduces the response time to access content, and increases the subsequent reliability of delivery. This ensures that end user requests to the origin server are promptly and consistently responded to, providing a good quality of experience (e.g., web pages load quickly, video services stream reliably). This is shown in Figure 2.2.

Figure 2.2: Introduction to the function of a CDN [Source: Analysys Mason, 2023]

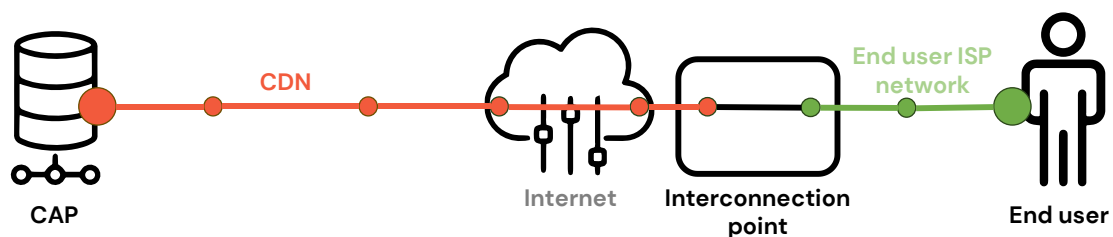

In addition, CDNs may build on this traffic routing and prioritising approach and also deploy a local copy of frequently accessed content in a cache, close to end users, as shown in Figure 2.3. The use of the cache replicates content and applications from the source to a point closer to the end user. For content and applications that are used frequently by end users, their storage in the nearby cache provides further improvements to the end user experience. This further reduces the traffic demand on the network between the source and the point of interconnection, because traffic between the end user and the cache does not need to go through the entire network.

Figure 2.3: Use of cache functionality within a CDN [Source: Analysys Mason, 2023]

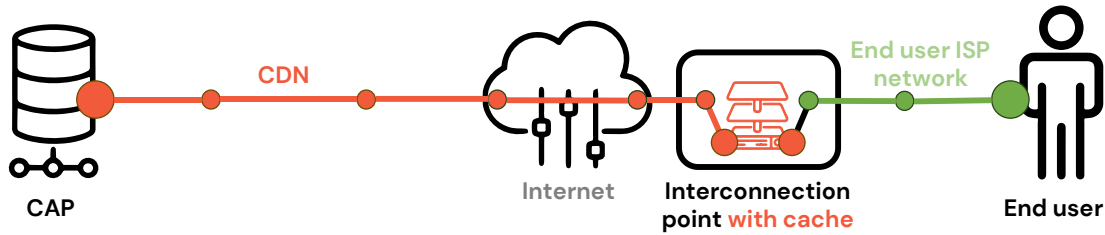

Some caches are embedded within ISPs’ networks, even closer to the end user, which unlocks further cost savings for the ISP, whose network is less utilised than if the content was served from the CDN through a point of interconnection.<sup>6</sup> We explore this dynamic in more detail in Section 3.1.

Overall, public CDNs deliver significant benefits to end users by ensuring that content is promptly and reliably delivered. The function of CDNs is critically dependent on the interconnection relationship with ISPs, which have historically developed on a freely negotiated basis between both parties.

### 2.1.2 Public CDNs are widely used by popular sources of content in Brazil

Public CDNs are widely used in Brazil, and support the delivery of a broad range of popular content, including media services. As mentioned at the start of the section, public CDNs are not themselves content providers, but act as intermediaries on behalf of these content providers to bring content closer to ISPs and end users. Large users of public CDNs include streaming providers, including some Brazilian media companies with an online video offering. Most streaming providers use multiple CDNs, and public CDNs each support multiple media companies. A summary of the usage of CDNs by media providers is shown in Figure 2.4. A few media providers also use their own CDN, which is exclusive to them.<sup>7</sup>

Figure 2.4: Summary of media providers and disclosed use of public CDNs in Brazil [Source: Netify, 2023, Velocix 2022, TIM Broadcast International, 2021]

Media Provider	Akamai	Amazon CloudFront	Edgio	Fastly	Google Cloud	Velocix	Qwilt
Amazon Prime		✓	✓				
Disney+	✓	✓	✓	✓			
HBO		✓	✓	✓			
Apple TV	✓						
Oi Play						✓	
Globo					✓		✓

<sup>6</sup> Some CDNs like Netflix Open Connect still rely on interconnection for embedded caches, but the logic is the same

<sup>7</sup> Apple TV and Globo also use their own (private) CDN

The multi-stakeholder way in which public CDNs are currently used by major media providers means that any change in how the public CDN market works, including the introduction of new regulation to mandate network usage fees, could have complex and unexpected effects. The use of CDNs by major media providers is supportive of the E-Digital's ambitions – in particular, supporting access to internet and digital technologies with good quality of service, and allowing the development of new business models (e.g. traditional telecoms operators or TV broadcasters reaching online audiences). Policymakers and regulators must ensure that any new regulation does not adversely affect this support provided by the use of CDNs.

## 2.2 Public cloud services are supporting critical industries and sectors

The role of public CDNs in facilitating the delivery of content requested by end users from a wide range of content providers mirrors the use of public cloud services, also by a wide range of companies across the Brazilian economy. This enables companies to benefit from the economies of scope and scale provided by sharing high-powered remote IT infrastructure with other enterprises.

Critical sectors of the economy are increasingly cloudified and, importantly, the use of public cloud services relies on the ability of their users to access public cloud platforms via their ISP, through the public internet or through dedicated cloud 'on-ramp' connections.

### 2.2.1 Public cloud services provide flexible access to high performance IT services

Cloud services can be defined as *“a model for enabling ubiquitous, convenient, on-demand network access to a shared pool of configurable computing resources (e.g., networks, servers, storage, applications, and services) that can be rapidly provisioned and released with minimal management effort or service provider interaction.”*<sup>8</sup> Cloud services replace the 'on-premises' information technology (IT) equipment traditionally owned and managed by the organisation using the services.

This paper focuses on public cloud services, whereby the underlying storage and compute infrastructure, as well as the networking services required to access and use those services, are shared by multiple end clients. This approach allows each client to benefit from the economies of scope and scale provided by sharing the infrastructure with other users. Cloud services are also typically referred to as being 'elastic' for their clients: capability can be provided on-demand, with the cost of using the service a reflection of its actual use rather than a fixed cost as for on-premises IT.

The landscape of cloud services is built up of several layers, as shown in Figure 2.5.

<sup>8</sup> See Ofcom (2022), *Cloud services market study: Call for inputs*



Figure 2.5: Landscape of cloud services layers [Source: Analysys Mason, 2023]

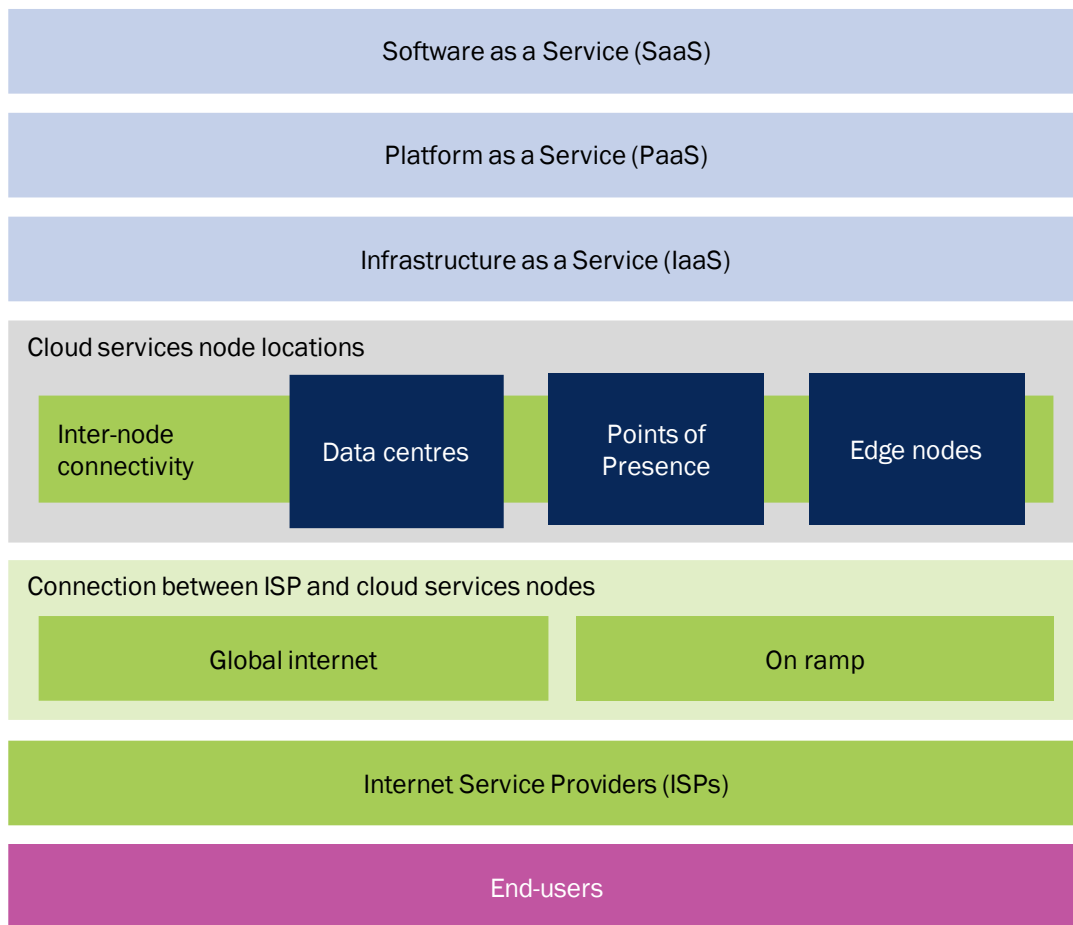

Each of the layers in the cloud services landscape is described as follows (working from the bottom of the diagram to the top):

*End users*                      The end users of public cloud services in Brazil are primarily businesses, ranging from small SMEs to large corporations and even government.<sup>9</sup> They are using cloud services to save costs and improve processes, develop new business models, and to support their growth. Some examples of how cloud services are supporting critical industries are given in Section 2.2.2.

*ISPs*                                ISPs provide the critical first two-way connection from the enterprise end user towards the network nodes where the cloud services are hosted. Good quality internet connectivity is essential for cloud services to be useful: if bandwidth is too low or latency too high, the experience of the user will be such that an on-premises solution may still be a better choice.

<sup>9</sup> ZDNET (2021), *Brazilian government concludes cloud integration tender*

*Connection  
between ISP and  
cloud services  
nodes*

ISPs connect the end user traffic to an interconnection point, at which point one of two things happens:

- The traffic may be delivered to and from the cloud services node locations via the public internet. This delivery is subject to the best-efforts service standards of the internet, and the overall end-to-end user experience of the cloud service may be affected by the route and number of ‘hops’ that the traffic needs to traverse.
- The traffic may be delivered to and from the cloud services node locations via an ‘on-ramp’ service. This provides an assured connection between the end user’s ISP and the cloud services nodes, meaning that applications which are sensitive to issues like latency can be run via cloud services. Cloud providers tend to partner with connectivity providers to provide on ramp services, and those connectivity providers will offer to collect traffic from ISPs in numerous locations. The on-ramp connectivity providers are sometimes the same organisation as the local ISP.

*Cloud services  
node locations*

The cloud services themselves are provided from a range of location types, including larger data centres, smaller points of presence where several networks interconnect, and smaller edge nodes that may only be a rack in a server room directly in the cloud user’s office. These locations are carefully planned to provide a balance between:

- concentrating resources in few locations (to deliver economies of scope and scale)
- ensuring redundancy (e.g. if the power supply fails to one node location, other node locations are unaffected)
- proximity to end users.

Larger node locations are connected by the cloud provider’s own network, which will feature high capacity and highly resilient links. Indeed, some cloud providers have invested in their own undersea cables to support this function. Smaller edge nodes may be connected over third-party connections, with the logical link to the cloud platform running over those third-party links (which may include standard open internet connections).

The node locations and inter-node connectivity work together to provide a single global cloud platform, which can support a very large number of applications and services from a very large number of individual enterprise end user clients.

*Infrastructure as a Service (IaaS)* Within some of the cloud services node locations, IaaS provides the option for end users to directly access cloud computing resources (i.e., central processing units, graphical processing units, memory) for processing workloads and storing data. Depending on the service selected, resources can be dedicated or shared between multiple users when in use, but in most cases these resources are allocated when needed and can be reused when not needed. This provides the elasticity and economies of scope and scale associated with cloud computing, compared to deploying on-premises computing resources.

*Platform as a Service (PaaS)* End users can also be provided with access to a virtual software environment where customers can develop, test, deploy and run applications. The service may include app development computing platforms, pre-built application components, and tools to build and manage full applications. In particular, PaaS may include services which are very difficult (or even impossible) for an enterprise user to deploy on their own, such as AI models and very large database systems.

The delineation between IaaS and PaaS is not always clear or easy to make, and these two types of services are nearly always offered and considered jointly.





*Software as a Service (SaaS)* The final layer is the provision of complete software applications that are hosted in the cloud and can be supplied by any vendor (including a cloud provider itself, as is the case for Microsoft and Google's productivity suites).



Irrespective of the type of cloud service used, the connectivity between the end user and the public cloud platforms is critical, and ISPs play a vital role in providing this two-way connectivity. If connectivity is impeded in any way, the user experience and utility of cloud services degrade, and high-profile outages or performance issues would affect the take up of cloud services across the economy.

### 2.2.2 Public cloud services are used in many sectors of the Brazilian economy already

Public cloud services are already underpinning some operations in important sectors of the Brazilian economy and society. Some examples of cloud services supporting key sectors are given in Figure 2.6.

Figure 2.6: Case studies of public cloud services supporting key sectors [Source: AWS, 2023, Google, 2023, Microsoft, 2023]

Sector	Company	Use of cloud services	Source
Finance 	Itaú Unibanco	Enhanced end-user experience including launch of new services and improved customer banking experience	<a href="#">Itaú keynote (amazon.com)</a>
	Boa Vista Serviços	Improvement in internal processes, including migrating information to the cloud, improved access to data, automation of operational work, increased number of analytical models and reduced prices of products	<a href="#">Boa Vista Serviços   Google Cloud</a>
	Banco Inter S.A (Inter)	Improved customer experience and technological infrastructure, including launch of new products, increased customer base, improved technological infrastructure and visibility of the technological stack	<a href="#">Banco Inter Case Study (amazon.com)</a>
Education 	Studos	Increased scalability and better user experience, including deployment of an educational and assessment platform and scalability to support multiple users simultaneously	<a href="#">Studos Case Study (amazon.com)</a>
Healthcare 	Hospital Israelita Albert Einstein	Enhanced patient satisfaction and improved internal processes, including scalability, elimination of downtime, improved patient experience, development of new solutions, reduced latency and faster deployment process for new features and version upgrades	<a href="#">Hospital Israelita Albert Einstein (amazon.com)</a>
	Grupo Oncoclínicas	Improvement in internal operations, including centralisation and better accessibility of data, facilitating decision making	<a href="#">Microsoft - Oncoclínicas</a>
Retail and consumer goods 	Beauty For All (B4A)	Optimised internal and customer facing processes, including automation of processes, improved consumer analyses, scalability, reduced costs, better customer experience	<a href="#">B4A Case Study   Google Cloud</a>
Technology 	Visio.ai	Scaling up of operations and cost reduction, including expansion of product portfolio, increased number of customers, higher service delivery speed, reduced inference costs and end-customer costs	<a href="#">Visio.ai Case Study   Google Cloud</a>

Sector	Company	Use of cloud services	Source
Telecoms 	Telecom Italia Mobile (TIM)	Improvement in customer satisfaction, reduced costs and implementation of new customer service solution	<a href="#">Microsoft – TIM</a>
Transportation 	Gol Linhas Aéreas	Optimisation of internal processes, including centralisation of data, increased operational efficiency and better decision making	<a href="#">Microsoft - Gol Linhas Aéreas</a>

These examples show that the capabilities of public cloud are already being used extensively by organisations in key sectors in Brazil, including service offerings from multiple operators. The use of cloud services by Brazilian enterprises is delivering against a number of the elements of the E-Digital strategy, including:

- access to digital technologies
- development and expansion of new technologies
- providing the cyberinfrastructure needed for large science and technology projects
- supporting a data-based economy
- supporting new business models
- promoting the adoption of ICT solutions for SMEs.

### 3 Public CDN and cloud services have a mutually beneficial relationship with ISPs

In addition to the benefit they bring to their users, whether companies or consumers, public CDN and cloud services have a mutually beneficial relationship with ISPs, including mitigating the impact of traffic on network costs and ensuring that internet services can be delivered at the right price. This contributes to stimulating demand for internet services, including cloud services. In this section, we also discuss the infrastructure investments that public CDN and cloud providers are making, as an essential complement to the investment in internet access networks.

#### 3.1 The benefits of CDN and cloud providers' services to ISPs

##### *Mitigation of traffic costs*

In addition to the benefits associated with the end-user experience, CDNs also deliver significant benefits directly to ISPs by reducing the traffic carried on the network 'upstream' of where the content is served from a cache. This effect is shown in Figure 3.1.

Figure 3.1: Traffic-alleviating benefits of a CDN [Source: Analysys Mason, 2023]

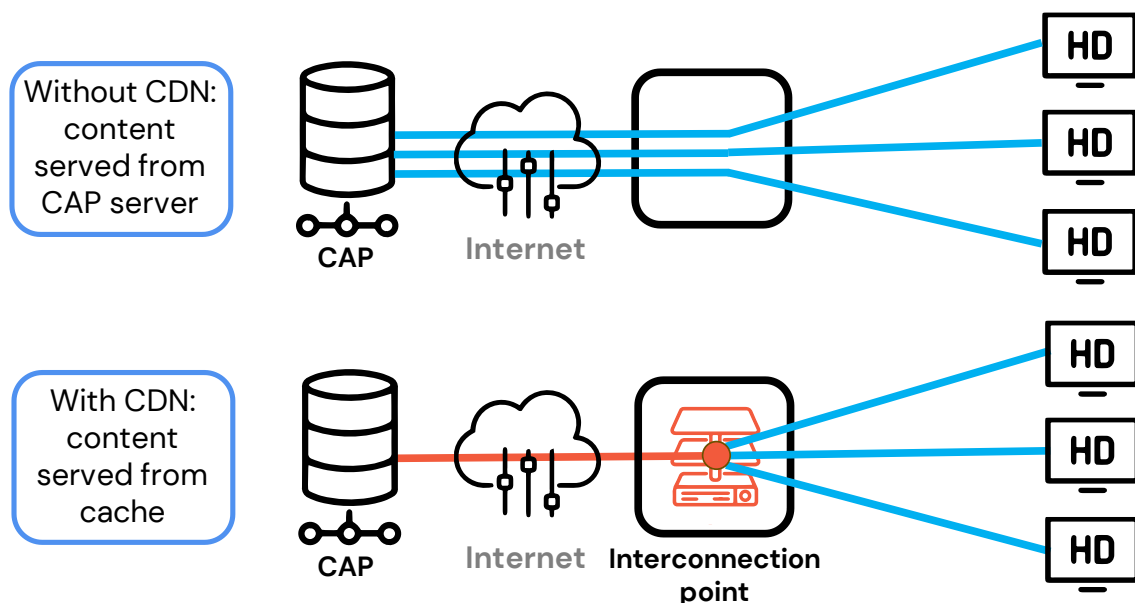

Without a CDN, each request for content must be served from the origin, creating large parallel traffic flows on the main national and international links. If the origin is in another country, the ISP will likely incur significant costs for international bandwidth or IP transit to bring the content back to their customers.

CDNs significantly mitigate this effect in two ways:

- By bringing the traffic to a point where it can interconnect with the ISP, the CDN ensures that the ISP does not have to pay for the transport of traffic to that point. Public CDNs charge the content provider for this service.
- The use of a cache also reduces the traffic flows on the core network links, removing the need for multiple parallel traffic flows if the same thing is being accessed by multiple people (e.g. a web page, or popular video content on a streaming service).

Overall, these dynamics reduce traffic costs in the core part of the network which, regardless of who pays, must eventually be passed on to end users.

A related effect is that CDNs also allow higher quality (e.g., higher definition video) content to be served to end users, because the high bandwidth traffic is kept on the more local parts of the network, which tend to be less congested or have more available capacity. It should be noted that most streaming services use adaptive bitrates that automatically reduce quality when networks become congested, but this behaviour would be more prevalent without public CDN services.

This benefit is increased if the CDN cache can be placed closer to the end user. Indeed, many public CDNs place their caches within an ISP's network, and this practice is seen in Brazil today. This reinforces the mutually beneficial relationship: end users benefit from high-quality services, benefitting both content providers and ISPs, and ISPs also benefit from lower core-traffic costs.

Placing caches deeper into ISPs' networks takes significant investment from CDN providers and is the object of commercial negotiations with ISPs. Just as there is no regulation currently in place mandating content providers to pay ISPs, there is no regulation forcing ISPs to agree to host embedded caches, or even to interconnect them close to their end users; nevertheless, market dynamics have led to many CDNs and ISPs collaborating to embed caches and interconnect in places that result in lower overall infrastructure costs.

#### *Demand for access to the internet*

The benefits of CDNs to the experience of end users (as discussed in Section 2.1.1) support the ongoing utility of internet services, and therefore demand for access to the internet. This effect supports, in turn, the ongoing demand for the services offered by ISPs. Similarly (as discussed in Section 2.2.1), cloud services require effective two-way connectivity provided by ISPs, creating further demand for their services.

We note that many CDN and cloud services are provided over a common cloud platform (i.e. big CDN providers often also provide cloud services, and vice versa), as shown in Figure 3.2.

Figure 3.2: Support of CDN and cloud functionality by the same CDN platform [Source: Analysys Mason, 2023]

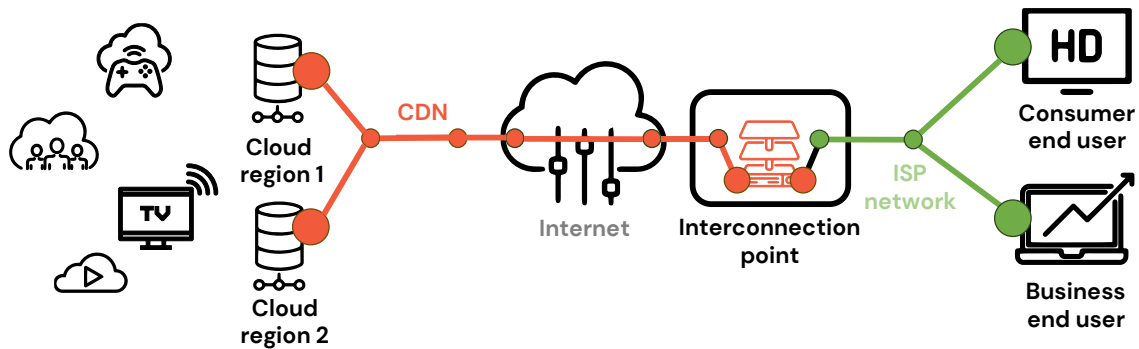

This dual functionality brings the benefits of CDNs to cloud services too. Even without the purchase of an additional on-ramp service, cloud services respond promptly enough to requests, giving a good quality of experience to users, despite being hosted remotely. This functionality further supports the take-up of cloud services, which is good for ISPs, as it drives a need for high bandwidth and high-quality connectivity between end users and the internet.

#### *Direct use of cloud services by ISPs*

A final benefit to ISPs is possible as they begin to make direct use of cloud services themselves. Some cloud services providers are working with ISPs (especially mobile network operators, MNOs) to help them develop new services and lower their costs:

- The migration of ISP IT workloads, such as central support systems and some core network systems, from their on-premises equipment to cloud infrastructure can bring reduced operating and capital costs.
- Some MNO ISPs around the world are working with cloud providers to transfer network functionality from base stations to ‘edge’ cloud infrastructure to realise further savings. The close proximity of these edge locations to end users delivers very low latency computational performance, meaning that the sensitive base station functions can be replicated in this way.

Across both of these trends, a migration of ISPs’ functions to cloud can also reduce energy consumption (and therefore carbon emissions), due to the high energy efficiency of cloud computing equipment.

Some examples of mobile ISPs working with cloud providers in Brazil include:

- Telefônica Brasil (Vivo) has worked with AWS to conduct a trial of a 5G standalone cloud native core solution.<sup>10</sup>

<sup>10</sup> CommsUpdate (2021), *Vivo trials Cloud Native 5G SA with AWS*



- TIM Brasil has chosen Oracle and Microsoft for the migration of its data centre workloads to the cloud, which is designed to improve customer support as well as billing, collection, and management applications.<sup>11</sup>

### 3.2 Cloud and CDN providers have invested significantly to support internet services

Key to the benefits explained above (for both end users and ISPs) are the ongoing investments made by CDN and cloud providers in the infrastructure used to support their services. This infrastructure includes servers, caches and data centres.

Following such investment, Brazil is now well served by a large number of locations featuring equipment from public CDN and cloud providers. These locations are in strategic towns and cities across the country, as shown in Figure 3.3.<sup>12</sup>

Figure 3.3: Number of points of presence for selected public CDN and/or cloud services in Brazil  
 [Source: Operator websites, Analysys Mason, 2023]



<sup>11</sup> <https://www.oracle.com/news/announcement/oracle-cloud-tim-brasil-032421/>

<sup>12</sup> Companies included are: AWS, Azure, Tencent Cloud, Akamai, Vultr, IBM, Cloudflare, Edgio, Fastly, Velocix, Claranet, Oracle, CacheFly

Some recent highlights of CDN and cloud operators' investments in Brazil include the following:

- Akamai recently announced an expansion of its cloud computing network and announced Sao Paulo as one of the seven new core compute regions.
- In May 2023, the Brazilian subsidiary of China Telecom (China Telecom do Brasil) launched eSurfing Cloud services in Sao Paulo, which enables clients to connect to a global multi-cloud network of over nine public cloud nodes, over 200 CDN nodes and 30 proprietary edge cloud nodes.<sup>13</sup>
- Some providers have also been investing in building data centres in Brazil, including Microsoft which is building a new data centre in Sumaré to expand its Azure cloud region in Sao Paulo; and Tencent Cloud which launched its first data centre in Brazil in November 2021 to meet the increasing demand of digital services.<sup>14</sup>
- In September 2021, the Government of Ceara announced that Amazon Web Services (AWS) will launch its third edge location facility in Fortaleza which will host AWS, including CloudFront for its CDN offering.<sup>15</sup>

Some other examples of investments and expansion of operations by cloud and CDN providers include:

- new point of presence announced by CacheFly in Porto Alegre in January 2021
- cloud capacity increased by 200% by Vultr in Sao Paulo
- investment of USD100 million announced by Claranet in Brazil in 2021
- expansion of multizone cloud region announced by IBM in Brazil
- second cloud region opened by Oracle in Vinhedo
- points of presence announced by Cloudflare in 12 Brazilian cities in 2021.<sup>16</sup>

In summary, public CDN and cloud providers have been making significant investments in Brazil. These investments are a key component of those needed to support Brazil's digital development: it is not just investment in access infrastructure (e.g. fibre and 5G networks), but investment in the infrastructure required to make compelling and innovative content services readily available for access.

<sup>13</sup> <https://www.akamai.com/newsroom/press-release/akamai-expands-world-s-most-distributed-cloud-network-with-new-c> and Developing Telecoms (2023), *China Telecom subsidiary launches cloud services in Brazil*

<sup>14</sup> Data Centre Dynamics (2023), *Microsoft plans data centre in Sumaré, Brazil* and S&P Global Market Intelligence (2022), *Latin America home to 10 new cloud regions since onset of COVID-19 pandemic*

<sup>15</sup> Data Centre Dynamics (2021), *AWS to launch Edge location in Fortaleza, Brazil*

<sup>16</sup> <https://www.cachefly.com/more-new-pops-in-latam/>, Data Centre Dynamics (2023), *Vultr expands Brazil cloud capacity by 200%*, Latin America Business Stories (2021), *UK-based Claranet invests \$100 million to expand cloud computing in Brazil* and <https://blog.cloudflare.com/expanding-to-25-plus-cities-in-brazil/>

## 4 Imposing fees risks harming the development of Brazil's digital economy

Because of the importance of public CDNs in the functioning of the internet, including as part of a broader set of public cloud infrastructure and services, any policy change that would significantly alter the incentives and economics at play will reverberate throughout the internet ecosystem, and beyond to the rest of the economy.

Mandating network usage fees would be one such major policy change. Levying network usage fees on traffic would likely have negative impacts on the incentives of cloud and CDN providers to invest and interconnect in places that optimise cost and quality. It also risks creating a 'snowball' impact on the organisations who rely on public cloud and CDNs, if the reduction in quality or increase in cost results in a loss of utility and value for them. Finally, there are significant challenges involved with implementing such fees in the first place, which are more than mere practical issues and go to the heart of how the internet works, and will have to be addressed not only by ISPs, public CDNs and cloud providers, but also very likely by regulators who will inevitably be called upon to arbitrate disputes and set rates directly.

### 4.1 Mandated fees on public CDNs and cloud providers would result in adverse incentives to invest, more capacity bottlenecks, and higher prices to their users

As a starting point, the imposition of network usage fees will impose an additional cost on cloud and CDN providers. This may, in turn, lead them to make several changes to their operations and investments: the fees may lower their ability and incentive to make infrastructure investments in Brazil, and they may seek to pass the increased fees on to their subscribers in the form of higher prices (or fewer bundled services). Both reactions will have a material impact on users, which we further examine below.

#### *Reduced investment in infrastructure and more centralised architecture*

Having to pay network usage fees may reduce resources and incentives to invest in more decentralised and localised infrastructure: if the ISP can levy a fee at point A or point B irrespective of whether it is they or the public CDN who brings the traffic from A to B, then a public CDN provider may prefer to avoid the cost of transmission and let just the ISP invest, leading to reduced infrastructure investment overall.

Furthermore, faced with such fees, public CDN and cloud providers could choose not to bring their traffic or services into Brazil at all, either for some or all ISPs. For some content, ISPs may have to collect traffic through transit or by peering in a location outside Brazil, increasing their international network costs. This effect is shown in Figure 4.1. There are examples of mandatory charging resulting in this effect,

both for interconnection as discussed below, and for other areas of the digital economy such as when charges have been imposed on search and social media providers for news links.<sup>17</sup>

Figure 4.1: Illustration of the effect of network fees reducing the incentive to deploy CDN and cloud infrastructure in Brazil [Source: Analysys Mason, 2023]

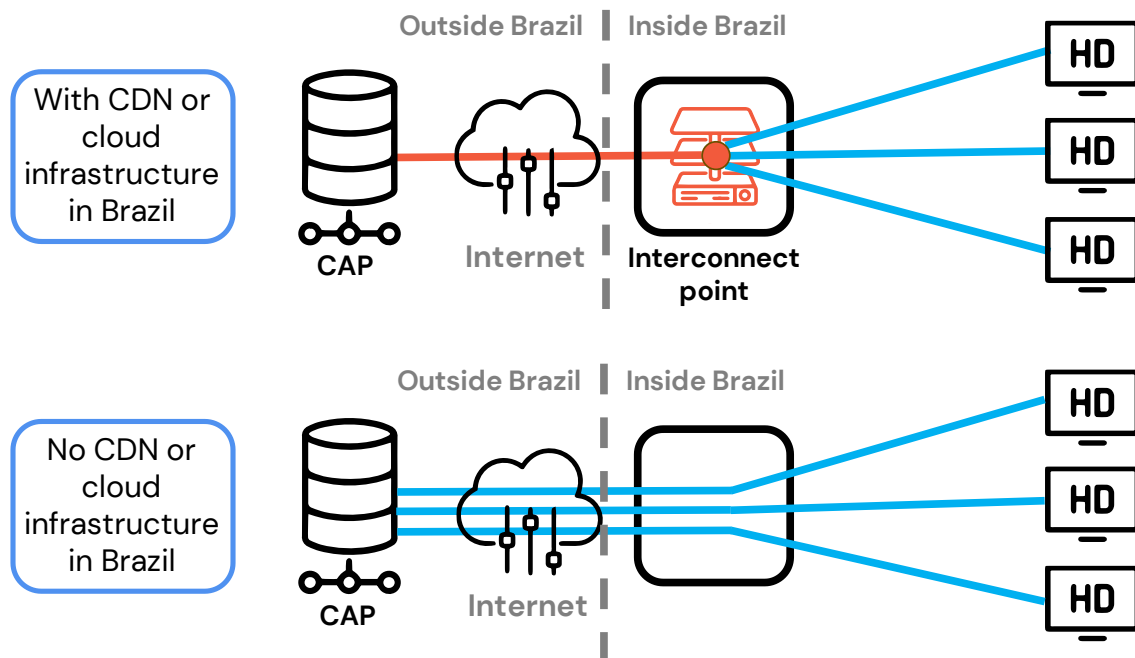

Reduced network investment on the part of cloud and CDN providers will not just affect ISPs, but ultimately will affect end users. Where an ISP has to connect to another country to exchange traffic with a certain provider, that traffic risks experiencing higher latency and lower resilience than if they had connected nearby. If this link is a transit link rather than a direct link, further hops between networks would exacerbate these issues and make it very difficult to manage the quality of experience for end users.

This situation played out in South Korea, when interconnection payments for internet traffic were imposed between ISPs, and in at least one documented case passed on to a content provider (Facebook, now Meta). That content provider shifted its traffic to be picked up by several ISPs in Hong Kong. The regulator fined the content provider, but the fine was overturned in court, upon which the law was amended to require content providers to make sure that their services remain 'stable' in the country.<sup>18</sup> This example shows one type of unintended consequences that can result from the imposition of regulated traffic fees in markets where there is no market failure. Another example is the recently announced withdrawal of Twitch's game streaming service from South Korea entirely, citing network fees specifically as a barrier to running a financially-viable

<sup>17</sup> See for example Ars Technical (2023), *Google tells Canada it won't pay "link tax," will pull news links from search* and The Guardian (2014), *Google News Spain to be shut down: what does it mean?*

<sup>18</sup> Internet Society (2022), *Internet impact Brief: South Korea's interconnection rules*

service (Twitch had been using CDNs, but the costs were passed the through by the CDNs to Twitch).<sup>19</sup> While the Meta example does not include CDN or public cloud services, it does also show how the imposition of network fees can have a detrimental impact on the dynamic set of services that make up the internet ecosystem.

Regardless of how the network usage fees are implemented, they are likely to have a greater impact on smaller ISPs. In particular, cloud and CDN providers will have less incentive to build out infrastructure, which has an element of fixed or capacity-independent cost, towards smaller ISPs, as they have fewer subscribers and therefore a smaller return on investment. This will require the smaller ISPs to use resources to access the content and services in other countries, potentially using international transit services, as happened in South Korea, with a higher cost than for domestic connections. Further, even if larger ISPs do access content overseas, they will have greater economies of scale to do so, and may have their own capacity, lowering the relative cost for larger ISPs.

#### *Higher prices or fewer bundled services*

Another potential impact of network usage fees related to the treatment of public cloud and CDN providers. If they are treated as counterparties to ISPs with regards to the fee, they would have to pay the ISP directly, and then pass part or all of the increased fees on to their customers. If all traffic was treated equally, it would result in all public cloud and CDN users seeing prices increase. In South Korea, we understand that regulation on network fees led to public CDNs offering services at a materially higher price than for content delivery in other Asian countries, to all their customers. As a result, it is sensible to assume that such an increase in price would likely affect all CDN users in Brazil if public CDNs and cloud providers were themselves faced with network fees.

If traffic has to be treated differently depending on the content provider or service, this could also be technically challenging, as discussed further in Section 4.3. Currently, public CDNs and cloud providers do not record traffic flows between individual customers and individual ISPs. If network usage fees are levied based on traffic flows measured by ISPs (and auditable by both parties), then public CDN and cloud providers may have to pay on behalf of their customers, and would need to pass these costs on to these customers.

Public cloud and CDN providers may also pass on higher costs by changing the structure of their service portfolio, making it more difficult for smaller customers in particular to get access to more advanced and innovative functionalities that they cannot yet justify, but would benefit from in terms of their research, development and innovation.

---

<sup>19</sup> <https://blog.twitch.tv/en/2023/12/05/an-update-on-twitch-in-korea/>

## 4.2 Snowball effect on businesses, public-sector cloud users and consumers

This debate over network usage fees is commonly framed as taking place between two large sets of companies – content and service providers on the one hand, and ISPs on the other – with ISPs focusing on the quantity of traffic being exchanged with specific content providers, and on the absolute size of larger content providers. In Europe, the targeted internet companies are portrayed as ‘tech giants’ by the proponents of network usage fees,<sup>20</sup> and as ‘large traffic generators’ in the EU consultation paper.<sup>21</sup>

However, it is important to keep in mind the source of the traffic being generated. Public cloud and CDN providers, for instance, are receiving traffic from, and delivering traffic to, a variety of organisations and consumers, they do not ‘generate’ traffic in any meaningful way. For example, when a TV company uses a public CDN to manage the delivery of its on-demand video streaming, even when the origin of the content is within the public CDN’s network (e.g. on a cache), the content is still ultimately requested by the end user from the TV company: the CDN is just an intermediary facilitator in this relationship.

Businesses large and small are increasingly using cloud services to run their operations, and interact among themselves, with their suppliers and their customers. They are turning to cloud services for a number of reasons, including that they help to manage IT costs of the organisation and may provide higher capability, security and resilience than operating and maintaining their own computer services. The same is true for government, non-profits, and other organisations that increasingly rely on cloud services. Organisations also increasingly use CDNs to deliver content to end users. This includes media companies delivering video content online (see Section 2.1.2), as well as software companies delivering upgrades, website content and other online services.

To the extent that cloud and CDN providers reduce their infrastructure investments, the latency of their content delivery and services may increase, and they may become less resilient as ISPs have to find other means to access the content. This also has a negative impact on the businesses and consumers of the cloud services and CDN content. High latency has been shown to reduce engagement with services, such as e-commerce websites, and a lack of resilience can impact the ability of organisations to engage in online activities.<sup>22</sup>

Ultimately, however, the impact is likely to fall primarily on end users, who increasingly rely on the internet for their work, social engagement, interaction with government and entertainment. Email, software access, social media, data storage, gaming, video streaming, and almost any other online

<sup>20</sup> See, for instance, ETNO (2023), *9 questions and answers on the “fair contribution” debate*

<sup>21</sup> European Commission (2023), *Results of the exploratory consultation on the future of the electronic communications sector and its infrastructure*

<sup>22</sup> Two studies from as early as 2017 can illustrate this point: Popescu et al., University of Cambridge (2017), *Characterizing the impact of network latency on cloud-based applications’ performance* and Akamai (2017), *Akamai Online Retail Performance Report: Milliseconds Are Critical*. As more and more workloads and real-time communication systems move to the cloud, the range of applications and their specific sensitivity to latency becomes more relevant to engineers and architects

activity, increasingly rely on a combination of cloud and CDNs. Cost increases may be passed on to end users, who will also feel the effects of any decrease in infrastructure investments. As demand for online services including cloud may slow, the impact of the network usage fees can begin to multiply at the expense of the benefits of digitalisation to the economy and society.

### 4.3 Technical and practical challenges with imposing regulation

#### *Mandated or negotiated fees*

A further challenge in imposing such a policy is deciding whether the regulator should set the network usage fee or whether it should be negotiated between providers (while the principle of a fee is itself mandated). In Europe, for instance, the providers who are in favour of network usage fees indicated support for introducing an obligation to negotiate such a fee, along with a dispute resolution mechanism and price monitoring.<sup>23</sup> This is reminiscent of how termination rates between MNOs were initially set in Europe, and that history suggests that they will eventually need to be directly set by the regulator, introducing another set of complications, as we discuss next.

Mobile termination rates (MTRs) were originally set by MNOs at high rates because of the ‘termination monopoly’. Each mobile operator effectively has a monopoly on terminating calls to its own current subscribers and thus, given the mandate to set its own rate, can charge other operators a high rate to do so. Furthermore, while a monopoly price is typically limited by the willingness of the buyer to pay the rate, in this case the MTR is paid by the calling party who subscribes to another network, thus removing this potential constraint on the level of the rate. The largest MNOs had another incentive to set high MTRs, to induce subscribers to switch to their network to take advantage of lower on-net calling rates to the largest set of subscribers and thereby avoid paying MTRs.

A similar dynamic could occur with the network usage fee. With a mandate to charge fees, ISPs would be free to negotiate high fees, knowing that they will be paid by the content and service providers, including cloud and CDN providers, and be passed on to their subscribers. To the extent that the public CDN and cloud providers are delivering content and services that compete with the ISP’s services – such as pay TV – such high fees may result in subscribers switching to the ISP’s services, reinforcing the incentive to set high rates.

Eventually, MTRs in Europe and elsewhere had to be set by regulators, to reduce the rates to cost-based levels, which required extensive and detailed cost models. The same is likely to be true for network usage fees, leading to a set of complicated decisions and costly cost models. The main question is what ISP costs the fees are meant to compensate. If it is simply traffic-sensitive costs, then those are low, and are already being addressed through infrastructure investments by public

<sup>23</sup> European Commission (2023), *Summary report on the results of the exploratory consultation on the future of the electronic communications sector and its infrastructure*

CDN and cloud providers, and in some cases compensated through negotiated paid peering agreements. Any other costs must be further justified and then translated into the cost models.

### *Practical challenges*

Regardless of how the network usage fee is set, there are still significant practical challenges with applying such a regime to public CDN and cloud providers, including:

- The choice of which increment of traffic to charge must be decided. Should it be the total amount of traffic that is delivered by the CDN/cloud provider to the ISP, including traffic that is delivered overnight when the networks are underused, or should it only be the traffic at peak times, which actually drives the required capacity of the network, and therefore the associated costs?
- How should the charge be applied in the case when the connection between ISP and public CDN/cloud provider is via the global internet, compared to traffic exchanged through a cloud on-ramp? Should the principle of charging not be two-way, in cases such as public cloud where the traffic originates from a cloud customer going through their ISP?
- Similarly, should the network usage fee depend on where the traffic is exchanged, with more charged the further the ISP has to carry the traffic? CDN and cloud providers interconnect with ISPs across a range of locations, onshore and offshore, in public or private peering locations, and embedded in the ISP network – all of these involve different costs and benefits for both parties.
- Should public CDNs and cloud providers who carry data on behalf of their customers be charged by ISPs, or should ISPs directly charge those customers? We note that, in our understanding, there is currently no mechanism for traffic or bandwidth to be recorded for individual public CDN customer traffic being exchanged with an individual ISP, and in the context of internet exchange points, the interconnection fabric is explicitly shared between multiple networks interconnecting with one another, making it more difficult to attribute traffic flow.
- How would the web of interconnection arrangements between public cloud/CDN providers and ISPs, which includes both peering and transit agreements, be formalised and brought under the new regulated regime? At the IX.br internet exchange point (IXP) in São Paulo alone, there are 1656 peers exchanging traffic among themselves.<sup>24</sup> Most of these existing interconnection agreements are not likely to be formalised.<sup>25</sup> Imposing network usage fees on even a fraction of these agreements, and then across the other IXPs and data centres across Brazil, will be a significant undertaking.

<sup>24</sup> <https://www.peeringdb.com/ix/171>

<sup>25</sup> In a recent survey of over 17 000 global networks, including 1440 in Brazil, 99.998% of the over 15 000 interconnection agreements were informal 'handshake' agreements without a written agreement. Packet Clearing House (2021), *2021 Survey of Internet Carrier Connection Agreements*



Given these challenges, there are likely to be disputes, meaning ways to monitor the traffic and a neutral means of dispute resolution and/or arbitration should be in place. All of this requires resources on the part of the relevant providers as well as the regulator.

We note that the European Commission has refrained from introducing network fees before their current mandate ends in November 2024. It will be down to the next Commission to decide whether it explores the idea again, from 2025 onwards. Inputs to the consultation that informed the Commission’s decision included those from the European Telecommunications Network Operators’ association (ETNO), GSMA and Telefónica, whom all indicated that intermediaries such as CDNs should not be charged usage fees:

- ETNO and GSMA<sup>26</sup> stated “*intermediaries like commercial content delivery networks (CDNs) should not be considered LTGs [large traffic generators], but the traffic conveyed via such intermediaries should count toward the LTG designation threshold*”.
- On a similar note, Telefónica’s<sup>27</sup> response to the consultation stated “*traffic from CDNs is to be attributed to a specific TG [traffic generators]. Considering not all traffic measurement tools used by ECN [electronic communication networks] providers allow to attribute traffic to a specific TG, European Commission could impose a transparency obligation on CDNs and alike intermediaries to report source of traffic for a proper assessment of LTGs*”.

---

<sup>26</sup> GSMA and ETNO (2023), *Summary of the Joint Telecom Industry Response*

<sup>27</sup> Telefónica (2023), *Telefónica's contribution to the EU Commission's exploratory consultation*

## 5 Conclusions

We find that the imposition of network usage fees would create frictions, costs, and disruptions to a very dynamic set of services which require high investments. This could result in increased costs for the substantial number of organisations, enterprises and businesses, of a wide range of sizes and from a wide range of sectors.

The demand for online services is dependent both on the cost of the services and the quality of the online experience. Imposing network usage fees could adversely impact both elements, ultimately with a negative impact on end users. Today, providers, including public cloud and CDN providers and ISPs, continue to voluntarily negotiate interconnection arrangements, as they have done since the earliest days of the internet. As new generations of access technology are introduced and new services made available, the interconnection arrangements have continued to evolve to ensure that interconnection is mutually beneficial, a process that has held with the introduction and popularisation of cloud and CDNs. The introduction of network usage fees would tip the scale in favour of ISPs in those negotiations, at the ultimate expense of the end users of cloud and CDNs.

As the volume of internet traffic increased over time, including from cloud and CDNs, their providers began to make infrastructure investments to deliver the content closer to the ISPs, and in some cases to embed caches directly into the ISP networks. In part, this was to help lower the latency of traffic delivery and ensure a high quality of experience for their users. It was also in response to the requests of ISPs to compensate them for the costs of receiving the increasing amount of traffic. Peering arrangements continued to be negotiated, in some cases with no settlements, and in other cases, the result was paid peering in which settlements were made to the ISP receiving the traffic for their subscribers.

Imposing the requirement to negotiate a network usage fee would enable ISPs to raise the fees in light of the termination monopoly they would be able to monetise for reaching their subscribers. Regulating the rate of the network usage fee may lower the network usage fee, but impose its own costs on the regulator in order to set the fee, monitor traffic and arbitrate disputes. Regardless of how the fee is set, it reduces the ability and incentive of cloud and CDN providers to build out their networks, at the expense of the quality of experience, and in addition may be passed on to end users. As all end users are directly and indirectly the beneficiaries of cloud and CDNs, all would be negatively impacted by the imposition of network usage fees.

Brazil is developing well as a digital economy, but has some progress to make, in line with the goals of E-Digital. Public CDN and cloud services are supporting this progress, and therefore policymakers and regulators must ensure that any imposition of regulation does not adversely impede the ability of these services to underpin Brazil's digital ambitions.

While this paper has focused on the situation in Brazil, the overall conclusions on the detrimental impact of network usage fees would likely be similarly applicable in other countries, including those in the wider Latin America region.